



# ***I-PACE*** **CONCEPT**

---



THE FUTURE IS HERE

# CONTENTS



---

**F**or more than 80 years, Jaguar has been globally renowned as a maker of beautiful sports cars. Cars that have excited the senses, always been relevant and at the cutting-edge of technology.

The I-PACE Concept is a smart five-seat SUV and the start of a new era for Jaguar. It's as daringly designed and innovative as the cars that put Jaguar on the map, with technology that enhances our customers' lives. It sets a template for others to follow, just as we have always done.

Transportation will change more in the next decade than it has in the past 50 years, and we're prepared for that change. Just as Jaguar always has, we're ready to give our customers the technology they want and need, when they want it. More than that, we're making it smarter, cleaner and more efficient.

The Jaguar I-PACE Concept is the first step toward our future. The future is now.

---



## TEARING UP THE RULE BOOK

**T**he Jaguar I-PACE Concept previews a production car that will arrive at retailers in 2018. It will be a smart five-seat SUV; both a sporting performance car and a family vehicle rolled into one. Its groundbreaking design, performance, competitive range and charging times will make it an electric alternative to a traditional premium SUV.

The design and engineering teams at Jaguar have taken full advantage of the opportunities presented by electrification; a cab-forward, sporting driving position, exceptional interior space and, of course, zero tailpipe emissions and instant acceleration.

The battery pack and motors have been designed and engineered by Jaguar to deliver

outstanding efficiency, with an targeted range of more than 220 miles on the US EPA cycle. Charging is easy and quick, with 80 percent charge achieved in 90 minutes and 100 percent in just over two hours using 50kW DC fast charging.

The interior of the concept features premium materials and beautiful, tactile details that highlight British craftsmanship at its best. There is digital craftsmanship too, with two, super-intuitive touch-screens that serve up information where and when the driver needs it. Packed with proven Jaguar technology, the I-PACE Concept features exceptional ride quality, exhilarating handling and a 0-60mph time of approximately four seconds.



# TOMORROW'S WORLD, TODAY

*Jaguar Land Rover is committed to an electric future, starting with entry into the exciting world of the FIA Formula E Championship*

The investment in the Formula E racing program provides a real-world performance testbed for EV technology in a high-performance environment.

The series takes place on street circuits in the world's biggest cities - including Hong Kong, Paris and New York. Both the chassis and battery system are standardized, allowing the teams to compete with their own customized motor, inverter and gearbox. This program will accelerate the development of future Jaguar electric powertrains in several areas, including

thermal management, battery efficiency and transmissions.

Technology transfer in Formula E is significantly quicker than in other racing series. For instance, both the I-PACE Concept and the I-TYPE Formula E car use permanent magnet electric motors and pouch battery cell technology. By providing greater insight into electric technologies, the development work on both cars will be directly helping Jaguar Land Rover engineers make better electric vehicles.

## REVOLUTIONARY RESEARCH

*The Jaguar I-PACE Concept - the first electric vehicle from Jaguar Land Rover - is designed and developed from a clean sheet, but incorporates all of the learning gained from intensive electrification Research and Development projects*

From the 2012 Jaguar XJ\_e plug-in hybrid prototypes, to the 2015 Evoque\_e project - which is looking at future technologies that could have production potential from 2020 - engineers at Jaguar Land Rover have already amassed a wealth of knowledge into Lithium-ion cell design and chemistries, electric motor design and state-of-the-art battery and thermal management systems.

This learning - which will be accelerated with the Jaguar entry into the FIA Formula E Championship - will see a zero-emission, battery electric powertrain join the world-class family of ultra-clean Ingenium gas and diesel engines from Jaguar Land Rover when the production version of the I-PACE Concept hits the road in 2018.



# WHAT LIES BENEATH

*Under the skin, the I-PACE Concept is radically different from a combustion-engined car. Instead of a gasoline or diesel powertrain, it has a state-of-the-art electric propulsion system, designed and developed by Jaguar Land Rover for optimum performance and efficiency*

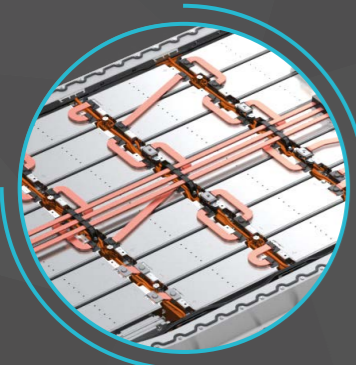

## > BATTERY PACK

The liquid-cooled 90kWh Lithium-ion battery uses the latest pouch cells, chosen because of their high energy density and excellent thermal management. It is positioned as low down as possible and right between the axles, dropping the center of gravity and improving vehicle agility.

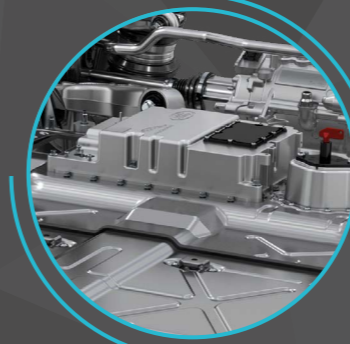

## > BATTERY MANAGEMENT SYSTEM

This highly sophisticated control unit is fundamental to the performance and range of the I-PACE Concept; it ensures the battery operates at optimum efficiency under a variety of conditions.

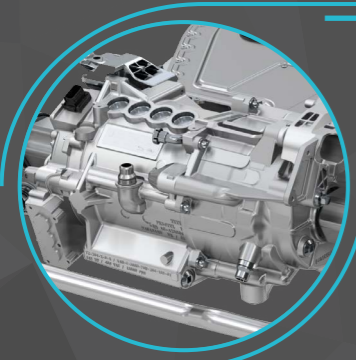
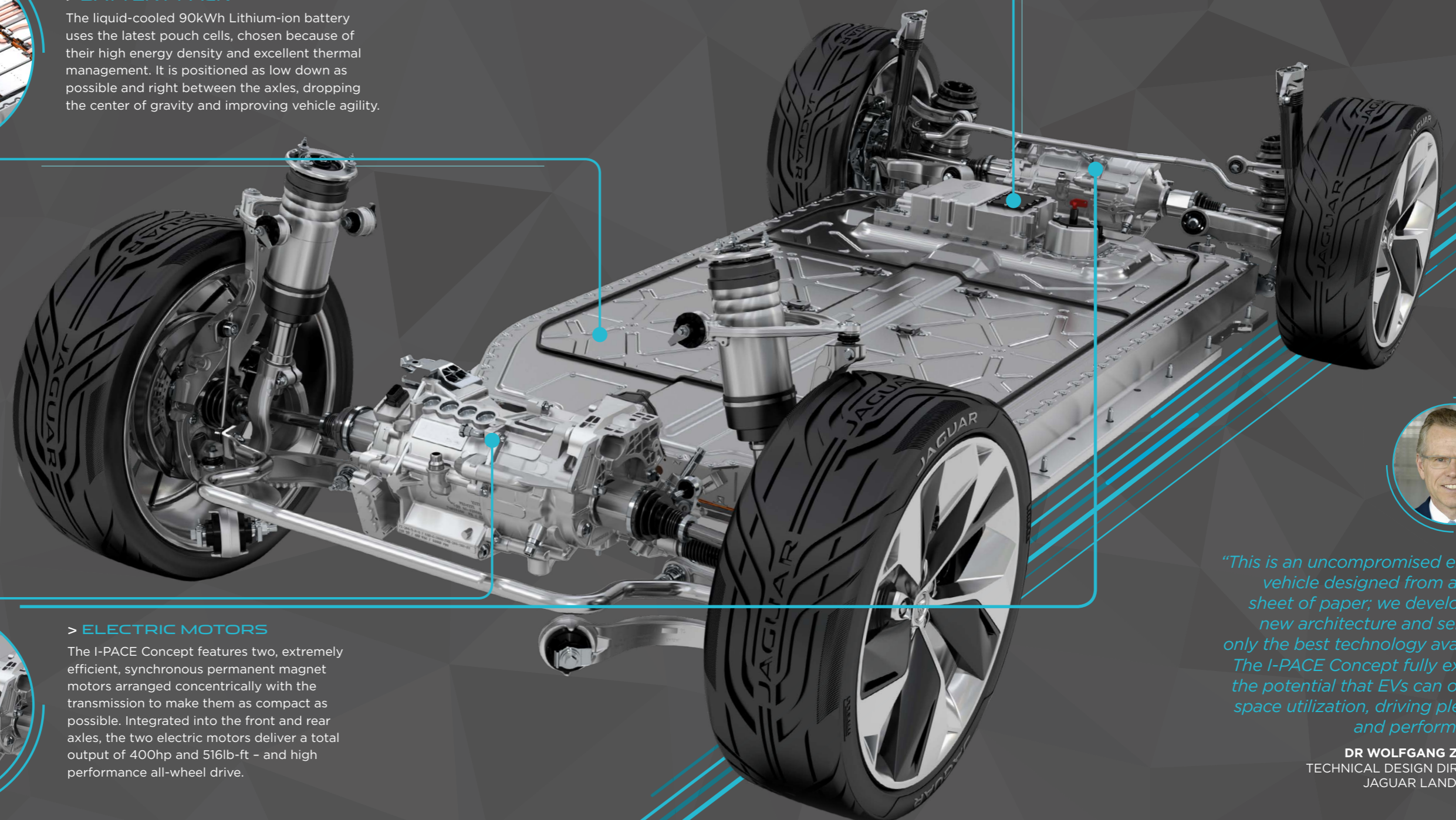

## > ELECTRIC MOTORS

The I-PACE Concept features two, extremely efficient, synchronous permanent magnet motors arranged concentrically with the transmission to make them as compact as possible. Integrated into the front and rear axles, the two electric motors deliver a total output of 400hp and 516lb-ft - and high performance all-wheel drive.



*"This is an uncompromised electric vehicle designed from a clean sheet of paper; we developed a new architecture and selected only the best technology available. The I-PACE Concept fully exploits the potential that EVs can offer in space utilization, driving pleasure and performance."*

**DR WOLFGANG ZIEBART**  
TECHNICAL DESIGN DIRECTOR,  
JAGUAR LAND ROVER



## FUTURE PERFECT

Bold, brave and undeniably beautiful, the Jaguar I-PACE Concept takes electric vehicle design into a new dimension. Its creator, Jaguar Director of Design Ian Callum, explains why it's been a career-defining project



“No other project I’ve worked on has given me the sheer thrill that this one did”

**IAN CALLUM**  
DIRECTOR OF DESIGN, JAGUAR



**W**ind back to early October, T-minus six weeks before the launch of the I-PACE Concept, and Ian Callum is in his office, with his red F-TYPE R parked in full view right outside. “It was a beautiful evening last night,” he says. “So I primed the iPhone with music and just went driving. Three hours around Warwickshire, Oxford and the Cotswolds. It was the most fantastic three hours, and I did think to myself: ‘Why don’t people get this pleasure out of driving anymore?’”

With Ian Callum it always comes back to the cars. A tireless enthusiasm for cars in general and Jaguar vehicles specifically is all part of Callum’s brand. It’s sustained him through a long and illustrious career defined by the creation of timeless, beautiful sports cars; deceptively simple silhouettes he’s gone on to translate into a range of timeless, beautiful sports sedans for Jaguar.

The I-PACE Concept is, however, something altogether new: not a traditional sports car, sedan or SUV and absolutely not a traditional Jaguar. Yet his approach to its design is absolutely traditional Callum; it’s informed by a sense of history, his scholarly understanding of form language and, inevitably, that overwhelming sense of enthusiasm.

“People tell me they think the car is going to change,” he starts. “Well, as long as we’ve got eyes in our heads and sit the way we do in cars, they’re not. What changes with a battery electric vehicle is the absence of mechanical machinery sitting in particular places. That’s the opportunity.”

“Now, if you give a designer a natural proportion of a sports car, they will tend toward a mid-cabin. We like the idea that people are sitting between the wheels. The old-fashioned notion was of people sitting behind the wheels, as it was with a horse and carriage. Suddenly, cars took on a completely new proportion in designers’ eyes. Mid-cabin is now the default silhouette designers want.”

Callum is of course best known for front-engined cars, but he’s nothing if not unsentimental. Not to mention adamant. “My favorite is still the C-X75 concept; you work around what you have. It liberates you to be able to put the people — who set the visual volume of the car more than anything — where you want them to be, which naturally is further forward. It’s practical to do so also; you get more space between the wheels when you’re not constrained by the engine package. But also we don’t like to see a lot of



mass over the back of the car. You want to push that mass forward; otherwise the car looks like it's falling back. That's just an instinct and so it was incredibly gratifying to have had the opportunity to do just that with the I-PACE Concept."

It's no secret that this is more than just a concept, hence the very public departure from the C-X concept prefix. Consequently, it's more than just an easy-on-the-eye shape. Callum long ago mastered the art of harnessing aerodynamics without becoming a slave to their unrelenting physics. Efficiency in battery electric vehicles manifests itself equally brutally: the more efficient the car, the further the range between charges and largely misplaced anxiety around range has in the past limited the appeal of battery electric vehicles. The I-PACE Concept puts up remarkably little fight against the wind.

"Aerodynamics is a huge challenge," he says. "You can't deny physics and it's always a sign of a good designer to ensure that the aero is as efficient as it can be within all the constraints remembering, of course, that one of the constraints is the aesthetic.

"It helped that the car was a whole new type of vehicle and there are no previous references. The profile helps the aero tremendously. If it was a very square, linear car — with vertical lines — the aero becomes naturally much more difficult. The back of the car relative to the front is very high and that is purely driven by the physics.

What air does when it leaves the car is actually the most difficult part to control. The back of the car especially was determined by aero requirements." There's little doubt that Callum has been inspired by the I-PACE Concept. It wasn't so long ago he was celebrating the launch of the second-generation XF, a landmark redesign as the



"I think what's really great about this car is that we didn't set ourselves any rules"

**IAN CALLUM**  
DIRECTOR OF DESIGN, JAGUAR

enormously successful first-generation car signaled the beginning of Callum's refashioning of Jaguar. And it's very clear – it always is with Ian Callum – that the I-PACE Concept is only the beginning. As he stands up to head to yet another meeting, it's evident that it is not just three-hour blasts in that red F-TYPE putting a twinkle in his eye. "I think what's really great about this car is that we didn't set ourselves any rules. Don't try and make it look like an F-TYPE or give it an E-Type boat tail because that's nice to have. Just accept the fact that this is a whole new Jaguar vehicle and takes the rules to a whole new level."

Opposite, clockwise from top left: the sharp rear end was dictated by aero efficiency; cleverly positioned ducts maximize air flow; distinctive "double-J" LED lights; the strong rear haunches enhance the car's athletic stance

The potential offered by electrification is greeted with great enthusiasm by Jaguar Advanced Design Director, Julian Thomson, who says that this is probably the most exciting era of car design he's seen in his career. "It's great to see the market opening up suddenly with alternative propulsion systems, but also totally different customers with totally different attitudes about how they use their vehicles." The future models taking shape in the Advanced Design studio will have to meet those demands. It's a challenge that Thomson clearly enjoys, but it's also one compounded by the fact that, however the design freedom inherent in electric vehicles is exploited, the result must still very obviously be a Jaguar and communicate performance, beauty and agility. The I-PACE Concept makes a very clear statement of intent.

"What surprised us was how readily this type of vehicle took to being a Jaguar," Thomson says. "And how natural it is for Jaguar to do this type of car. It shows how we can translate our values. Proportion, balance and stance are all there – all very important Jaguar characteristics that have to be absolutely perfect – but in a totally different form."

"What surprised us was how readily this type of vehicle took to being a Jaguar"

**JULIAN THOMSON**  
ADVANCED DESIGN DIRECTOR, JAGUAR



# PRIME NUMBERS

All the key facts about the I-PACE Concept

**0-60** mph  
takes approximately **4 SECONDS**

**12** inch

high-resolution Interactive Driver Display replaces conventional dials

**400** hp

Total power output from the front and rear electric motors

**220+**

mile range targeted to achieve on a single charge (US EPA cycle)

**184.25** in

Electrification and the cab-forward design deliver exceptional interior space within this compact length

**ZERO**  
TAILPIPE  
EMISSIONS

**90**  
MINUTES

Time taken to achieve 80% charge using 50kW DC fast charging

**516** lb-ft  
of instant, 100 percent torque for electrifying performance

**19** cu. Ft.

of loadspace in the luggage compartment plus additional space in the front storage area

**23**-inch

Nighthawk wheels in Technical Grey with Gloss Black inserts and a beautiful diamond-turned finish

**90** kWh

Lithium-ion battery pack, designed and developed by Jaguar Land Rover

**0.29**  $c_d$

drag coefficient thanks to a streamlined profile, aerodynamically-optimised rear-end design and details such as the flush door handles





## INSIDE LINE

With an unrivalled blend of cutting-edge technology and tactile controls, the I-PACE Concept showcases a vision for future Jaguar electric luxury



“The cab-forward design and electric powertrain were fundamental to the way that we created the interior.”

**ALISTER WHELAN**  
CREATIVE DIRECTOR, JAGUAR INTERIORS

**T**he striking and sophisticated interior of the I-PACE Concept redefines elegance and craftsmanship for the digital age, seamlessly blending technology, practicality and beautiful design.

“The cab-forward design and electric powertrain were fundamental to the way that we created the interior”, says Alister Whelan, Creative Director, Jaguar Interiors.

“They have allowed us to create a spacious and comfortable cabin environment with numerous opportunities for innovative storage and passenger space.”

Inspired by the F-TYPE sports car, the interior is driver-focused, incorporating the brand’s legendary sportiness into the purposeful stance of the I-PACE Concept. The driving position is much lower than a traditional SUV and this is accentuated by the dramatic, cantilevered centre console and slimline perforated seats.

Clean and uncluttered, the design combines handcrafted, high-quality materials with a light color palette. The Jaguar design team has also chosen to layer authentic materials for a unique look: dark, unvarnished walnut veneers sit flush with metal inserts to create seamless, textural contrasts.

Tactile features and finishes are as beautiful as they are intuitive. A perfect example of this is a new “flightdeck” approach to the cockpit, featuring three screens – two touchscreens in the center console and a virtual instrument cluster behind the steering wheel. Combine these with the gearshift buttons integrated into the floating metal legs, and it’s easy to see how the I-PACE Concept takes digital technology and usability to a whole new level.

To complete the interior, there’s a full-length panoramic glass roof, which floods the interior with natural light. In the daytime, the lozenge-patterned ceramic print matches the interior surface finishes, all to create a stunning visual effect that gives the I-PACE Concept its own distinct character.



# BEAUTIFUL DETAILS

*The I-PACE Concept is the first Jaguar to usher in a new interior design language focusing on features that blend digital craftsmanship with mechanical precision*



**01**  
**BESPOKE-FINISHED ROTARY CONTROLLERS**

*"There's a wonderfully tactile, haptic feel to the dials – just like a chronograph watch"*

**02**  
**LASER-ETCHED VENEER**

*"Beautifully crafted GPS coordinates locate the Jaguar design studio – birthplace of the I-PACE Concept"*



**04**  
**JAGUAR PRINT LABELS**

*"Showcasing the surprise-and-delight design ethos of Jaguar, these details symbolize the warmth and wit unique to this British brand"*

**03**  
**SIGNATURE LOZENGE PATTERN**

*"Our new heritage-inspired monogram design on the seats has a contemporary twist. It's a work of art in its own right"*

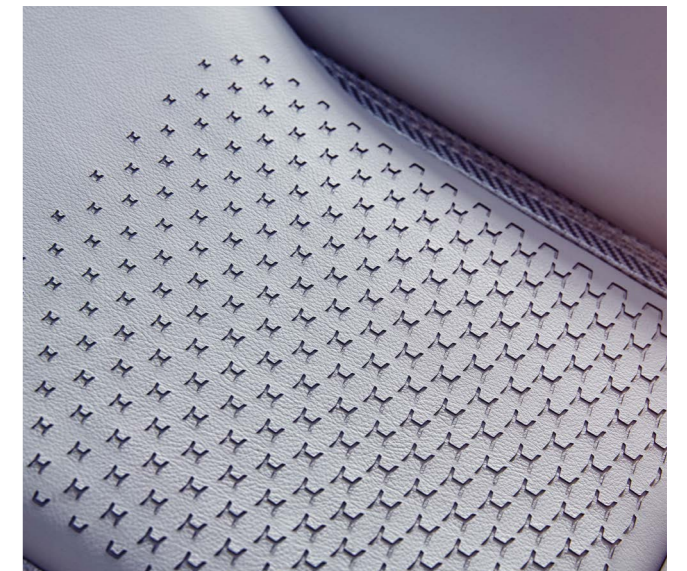

**05**  
**MERIDIAN SPEAKER TRIM**

*"At first, the precision-crafted Meridian lettering catches the eye; look again, and the detailed speaker pattern becomes clear"*

# PERFECT PACKAGE

*By fully exploiting the benefits offered by electrification, the I-PACE Concept tears up the rule book and offers more space inside than it could ever have done if powered by an internal combustion engine. The result is exceptional space efficiency and every day usability*

## > TRUNK SPACE

The compact design of the permanent magnet electric motors and the concentric transmission layout saves space compared to a conventional offset configuration. This enables the combination of a spacious cabin with an 19 cu. ft. luggage compartment.

## > REAR SEAT SPACE

The rear seats provide more kneeroom than vehicles from the segment above – and enough to match luxury sedans.

## > MORE SPACE

The electric vehicle concept delivers exceptional occupant space together with a longer wheelbase within a shorter overall length than conventional SUVs, and all within a dramatic, cab-forward design.

## > FRONT LUGGAGE

Because there's no combustion engine under the hood, the I-PACE Concept features a front luggage compartment instead, further increasing storage space.

## > CENTRE CONSOLE

With no transmission tunnel or traditional controller to package, the floating center console features almost 500 cubic inches of storage plus additional space for items such as phones. Further storage spaces are located under the rear seats.

## > FLAT FLOOR

Features such as the integrated cooling ducts in the sills and the lack of a transmission tunnel help to deliver a flat floor, while step-through in row-two is also greatly increased.

A silver Jaguar I-PACE Concept is shown driving on a winding asphalt road in a desert landscape. The car is positioned on the right side of the road, moving towards the viewer. The background features rolling hills and mountains under a sunset sky with warm orange and yellow tones. The road has a metal guardrail on the left side. The overall scene conveys a sense of motion and performance.

## ELECTRIC PERFORMANCE

With 400hp and 516 lb-ft of instant, electrifying torque, the I-PACE Concept is a true driver's car, a sporting Jaguar





**T**hroughout the process of creating the first purpose-built electric street car from Jaguar, the engineering team worked to a simple, single-minded mantra: the I-PACE Concept had to be a true driver's car.

To reach this goal, the I-PACE Concept features two incredibly compact electric motors designed by Jaguar Land Rover. Integrated into the front and rear axles, they offer a combined power output of 400hp and 516 lb-ft of torque, which is the same torque rating as the F-TYPE SVR. Together they also enable all-wheel drive, improving dynamics and traction on a variety

of surfaces and in a number of weather conditions. "Electric motors provide immediate response with no lag, no gearshifts and no interruptions," says Ian Hoban, Vehicle Line Director at Jaguar Land Rover. "Their superior torque delivery compared to internal combustion engines transforms the driving experience.

"With 516 lb-ft of torque and the traction benefits of all-wheel drive, the I-PACE Concept accelerates from 0-60mph in approximately after four seconds. The I-PACE Concept delivers searing performance, impressive ride and

"Electric motors provide immediate response with no lag, no gearshifts and no interruptions"

**IAN HOBAN**  
VEHICLE LINE DIRECTOR,  
JAGUAR LAND ROVER



“The I-PACE Concept accelerates from 0-60mph in around 4 seconds”

**IAN HOBAN**  
VEHICLE LINE DIRECTOR,  
JAGUAR LAND ROVER

handling characteristics. To achieve this, it uses the sophisticated double wishbone and Integral Link suspension setup proven in the XE, XF and the F-PACE.

It will stop just as efficiently, too: an electric brake booster replaces the normal vacuum servo, ensuring maximum flexibility in the brake system control and maintaining excellent pedal feel.

The electric motors and Lithium-Ion battery in the I-PACE Concept are designed to deliver the best possible performance and range. The I-PACE Concept delivers a targeted range of more than 220 miles on the US EPA cycle and, using 50kW DC fast charging, achieves zero-to-full charging capability in just over two hours; 80 percent charge capacity can be reached in just 90 minutes.

With this kind of range and efficiency, there's no doubt the I-PACE Concept is an electric vehicle that will perform in the real world and compete with vehicles powered by the best internal combustion engines.

# CONNECTED FEEL

*The sophisticated suspension design in the I-PACE Concept incorporates all of the lessons learned developing the F-TYPE and F-PACE, setting it apart from all other electric vehicles*

Using the proven double wishbone suspension at the front and Integral Link suspension at the rear, the I-PACE Concept delivers impressive ride, handling and refinement.

“When you get behind the wheel of the I-PACE Concept, the driving experience reflects the dynamic design,” says Mike Cross, Chief Engineer of Vehicle Integrity, Jaguar Land Rover. “It’s a true Jaguar, and we will prove that a zero-emission vehicle can be a true driver’s car.”

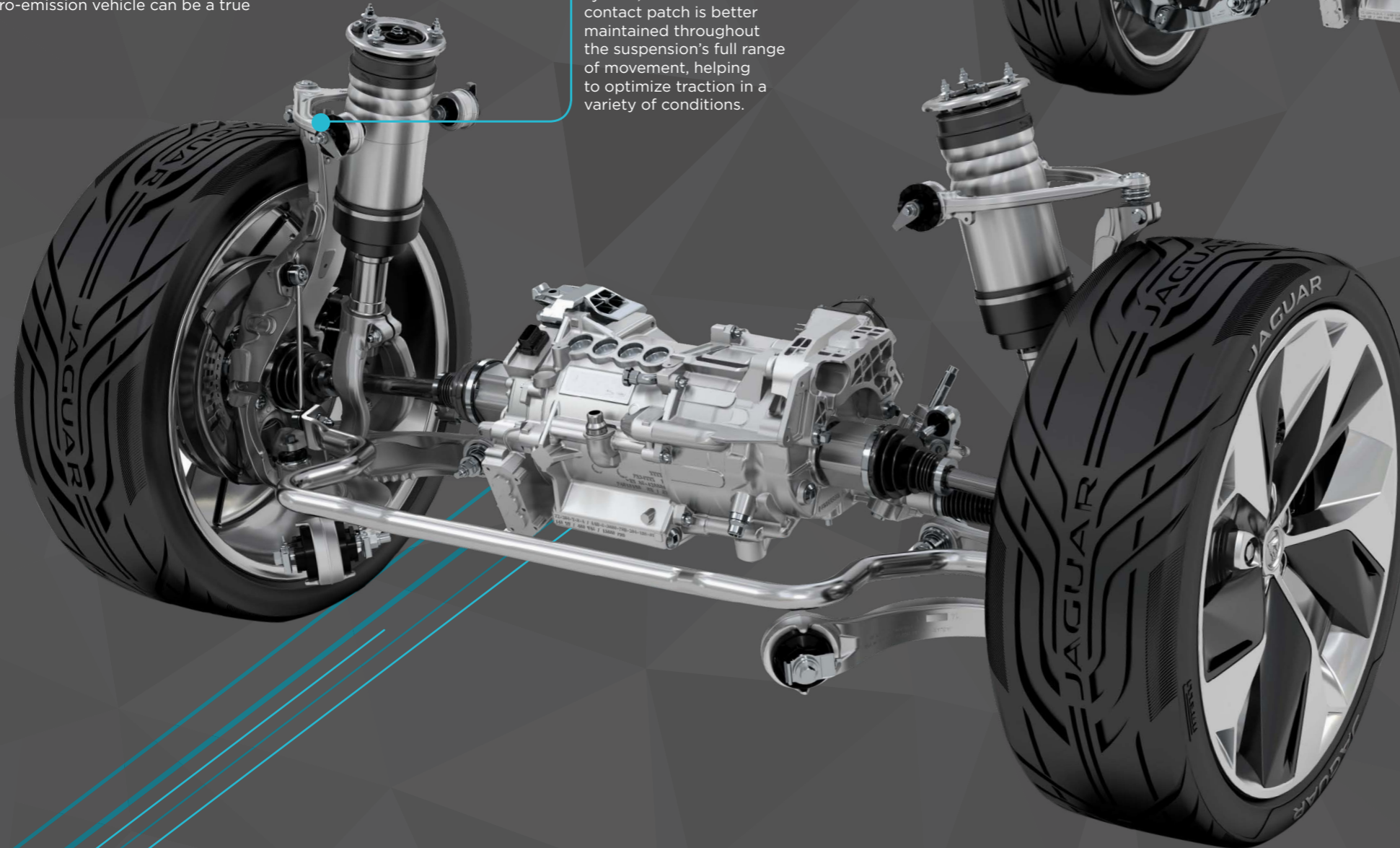

## > DOUBLE WISHBONE

The high camber stiffness afforded by the lightweight aluminum double wishbone design is fundamental to agility and responsiveness - lateral forces at the tires' contact patch build very quickly, and the steering responds immediately and precisely to the driver's every input. Because of the superior roll camber gain characteristic inherent to the double wishbone system, the tires' contact patch is better maintained throughout the suspension's full range of movement, helping to optimize traction in a variety of conditions.

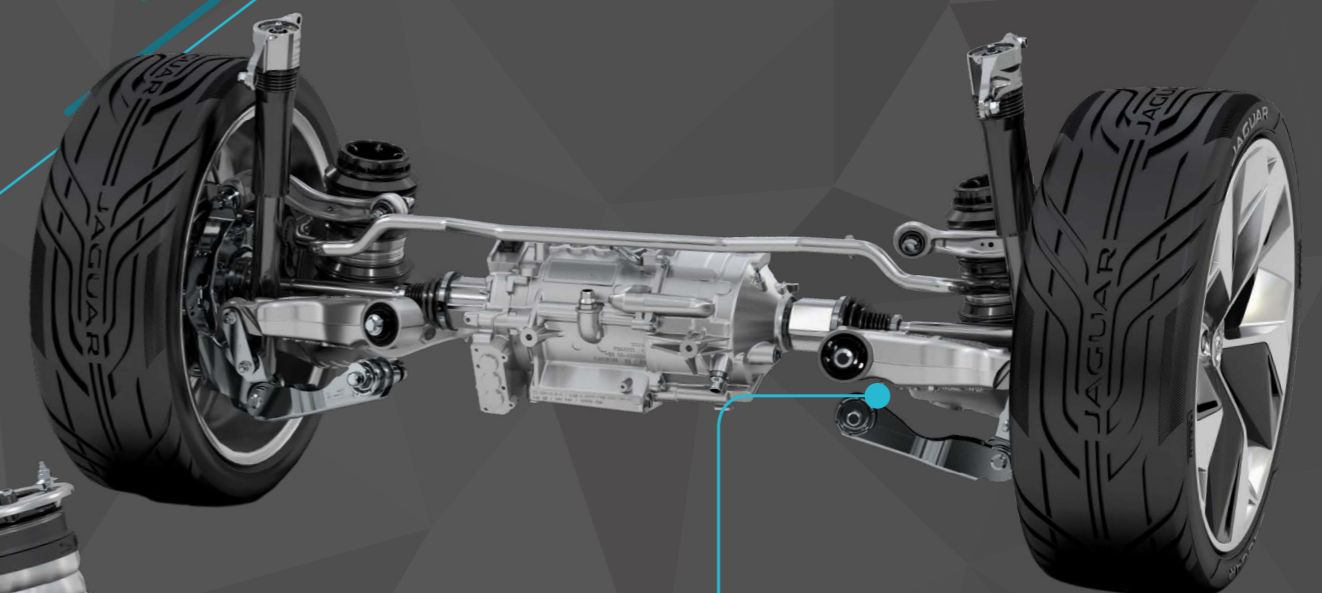

## > INTEGRAL LINK

This sophisticated, package-efficient design offers a unique balance of ride, handling and refinement. The Integral Link system enables chassis engineers to tune longitudinal and lateral stiffnesses independently. This means freedom to fully optimize comfort and dynamic attributes without one compromising the other. As a result, the bushes that manage longitudinal forces can be softened for better energy absorption, and therefore a smoother, quieter ride.

# POWER TO PERFORM

*Designed and developed by Jaguar Land Rover, the battery pack and electric motors enable optimum performance, efficiency and range*

## > BATTERY PACK

The I-PACE Concept features a liquid-cooled, 90kWh battery comprising 36 modules enclosed within a structural aluminum housing.

Each module contains the latest Lithium-ion pouch cells, which use Nickel-Cobalt-Manganese chemistry. These cells were selected for their combination of high-energy density and because they can maintain a higher current longer, which means that the battery can deliver both range and sustained performance. Compared to some other cell types, they also offer considerable future development potential.

The state-of-the-art thermal management system is designed to maintain the battery's optimum operating temperature window for maximum efficiency and durability.

A heat pump is an integral part of this system: by scavenging heat from the outside air to help warm the vehicle's interior, the heat pump can deliver a double-digit increase in range - even in freezing winter conditions, when needed most.

*"The electric motors are hollow permanent magnet machines which, together with the concentric transmission, offer the best power density and efficiency and the lowest weight: they give the I-PACE Concept sports car performance"*

*Dr Wolfgang Ziebart  
Technical Design Director,  
Jaguar Land Rover*

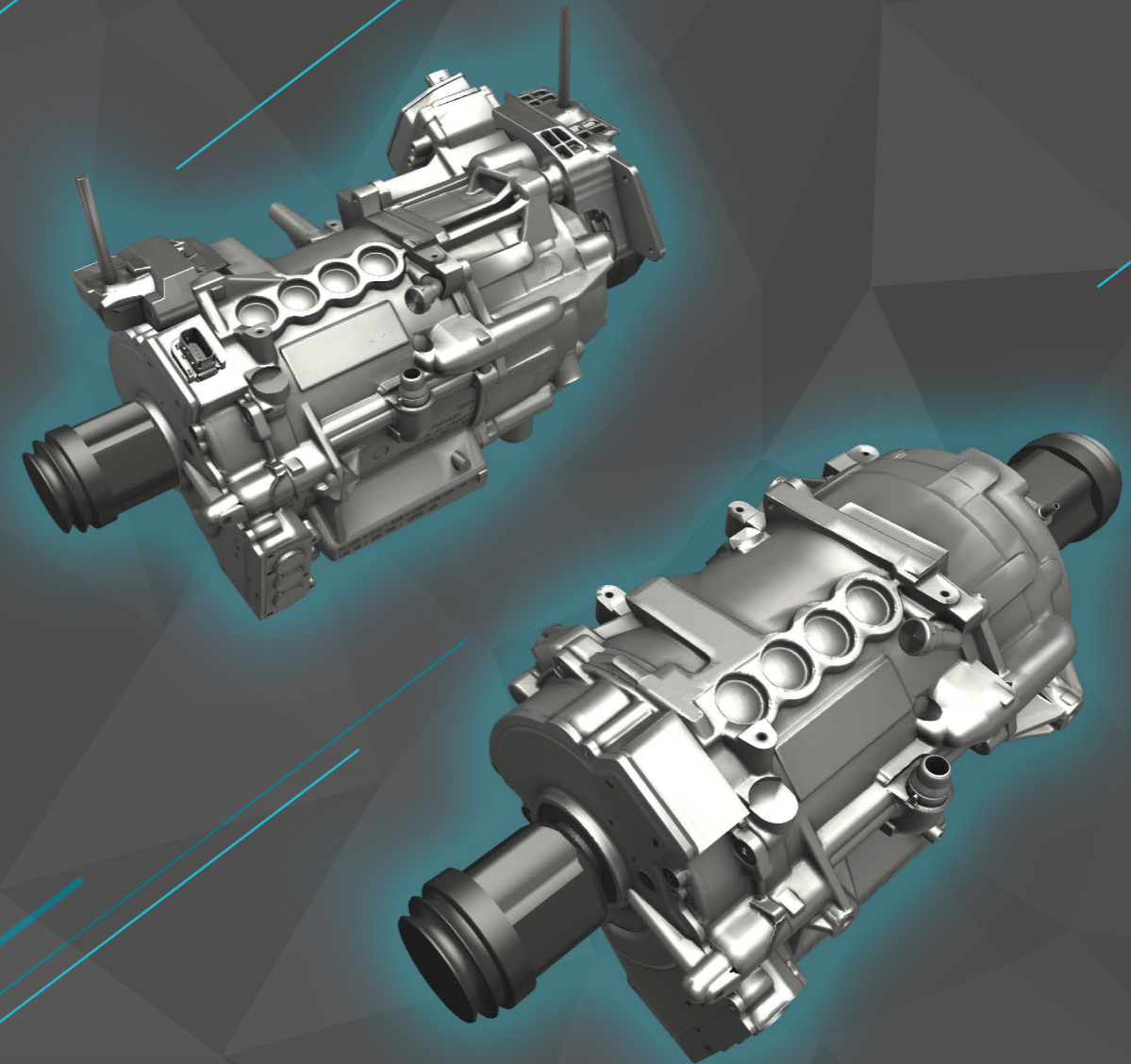

## > ELECTRIC MOTORS

The I-PACE Concept is powered by two synchronous, permanent magnet electric motors integrated into the front and rear axles. Each generates 200hp and 258 lb-ft of torque and is paired with a concentric, single-ratio transmission.

The driveshafts pass through the center of the motors because this is the most space-efficient layout possible: the motors have an outer diameter of just 9.21 in. and measure 19.68 in. long. These compact dimensions deliver packaging benefits within the vehicle, contributing to the impressive luggage compartment volume in the I-PACE Concept.

The motors are also light and extremely efficient, making them ideal for this high-

performance electric vehicle. Response is immediate, and this instant torque delivery combined with all-wheel drive traction enable the I-PACE Concept to accelerate from 0-60mph in approximately four seconds.

As soon as the driver lifts off the accelerator pedal, the motors provide regenerative braking, comfortably slowing the vehicle down and recharging the battery in the process. Using the Drive button within the transmission controls integrated into the center console, the driver can increase the level of regenerative braking, if desired. The corresponding increase in deceleration means that, in stop-and-go traffic, for example, the driver can drive with just a single pedal, with no need to apply the brakes to slow the car.



# DIGITAL DETAIL

The I-PACE Concept introduces a new intuitive "flightdeck" approach where multiple digital inputs combine seamlessly into one holistic driving experience

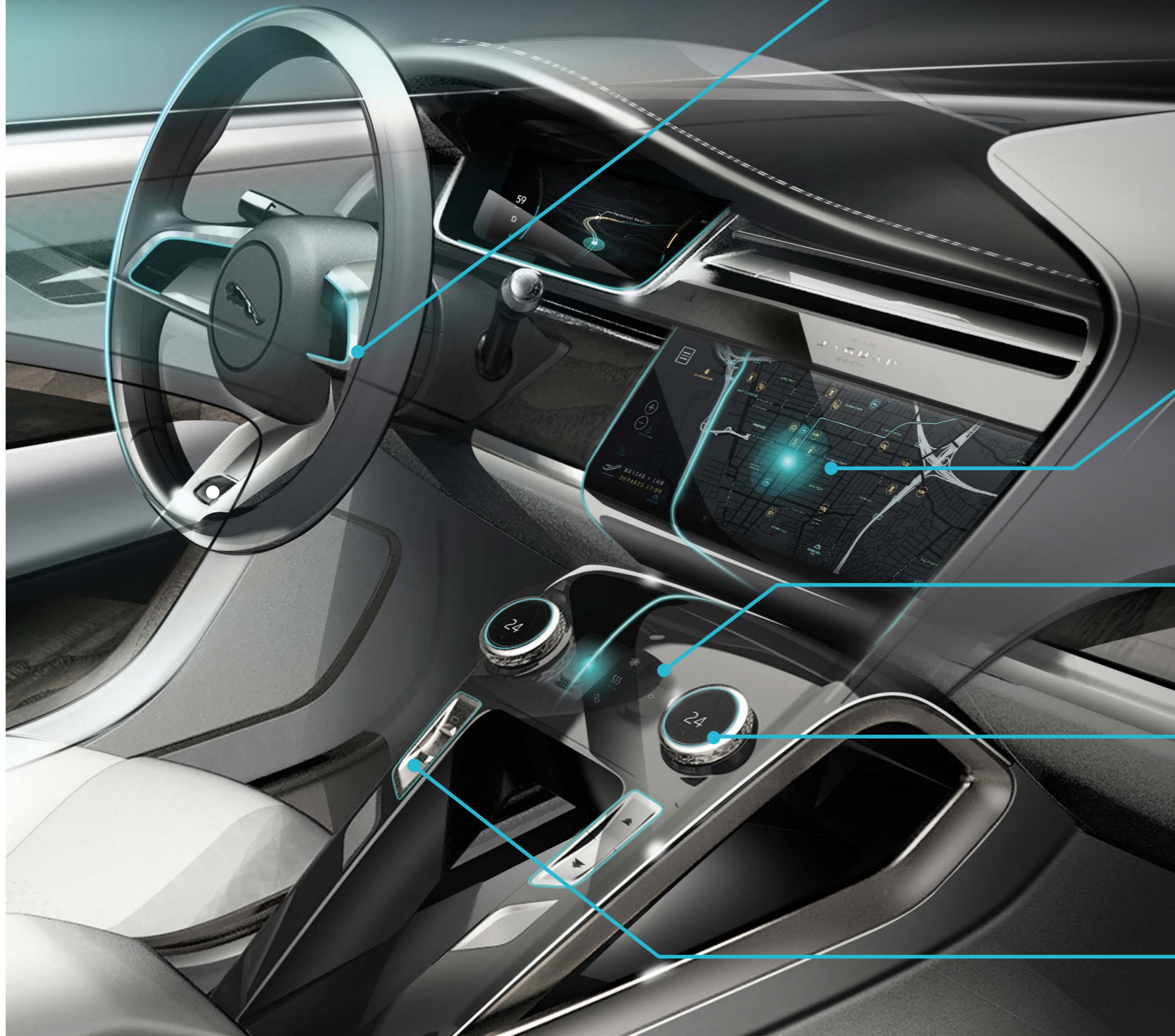

## CAPACITIVE SWITCHES

These hidden-until-lit controls enable a simple and engaging drive. To enhance the tactility, the flush switches also feature a "micro-click" haptic feedback when pressed.

## MAIN TOUCHSCREEN

The primary infotainment interface features high-definition pixel quality. The elegant digital interface was inspired by editorial and graphic design creating an intuitive "home from home" user experience.

## DIGITAL ROTARIES

A delightful blend of digital with analog. Precision-milled aluminum encases unique, HD circular displays, and the variable haptics help the driver differentiate between modes.

## LOWER TOUCHSCREEN

Falling perfectly to hand, this secondary touch point allows occupants to configure infotainment and climate settings, while keeping full-screen information on the main display.

## TRANSMISSION CONTROLS

Ergonomically-placed and space-efficient buttons replace the traditional shift lever, resulting in an entirely new center console philosophy focusing on sportiness, exceptional storage and usability.

# JOIN THE REVOLUTION

Be the first to register your interest in the I-PACE.  
Go to [JaguarUSA.COM](http://JaguarUSA.COM)

I WANT ONE >

All illustrations, photographs and specifications shown here are based on the Jaguar I-PACE concept vehicle. Final U.S. specifications, design, equipment, and accessories have not been determined. Therefore, U.S. production vehicles will differ from the one shown.

All pricing and figures for acceleration, power, speed, range and charging are Manufacturer's estimates based on best information available at time of publication. Jaguar I-PACE production vehicles will be tested and certified prior to release, with official figures available prior to any customer order. Production vehicles will be tested and certified prior to release, with official figures available prior to any customer order.

For more media information visit:  
[MEDIA.JAGUAR.COM/EN-US](http://MEDIA.JAGUAR.COM/EN-US)

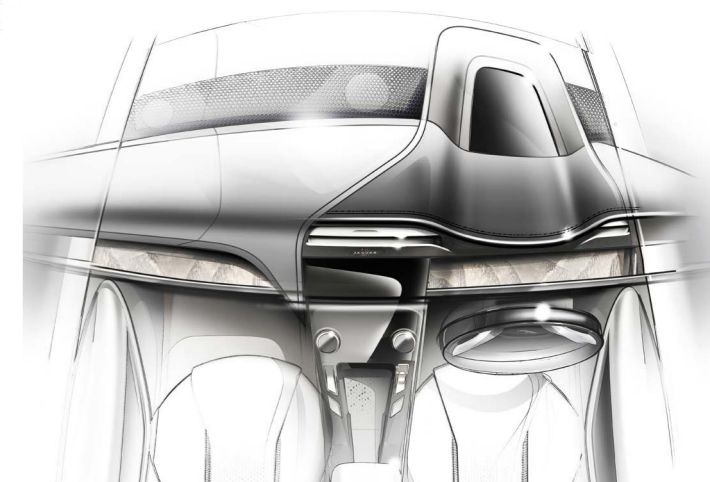
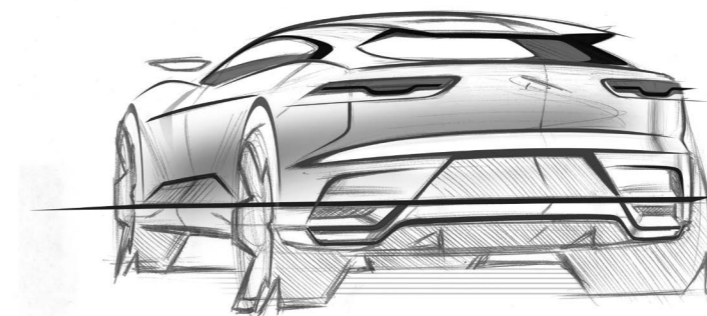
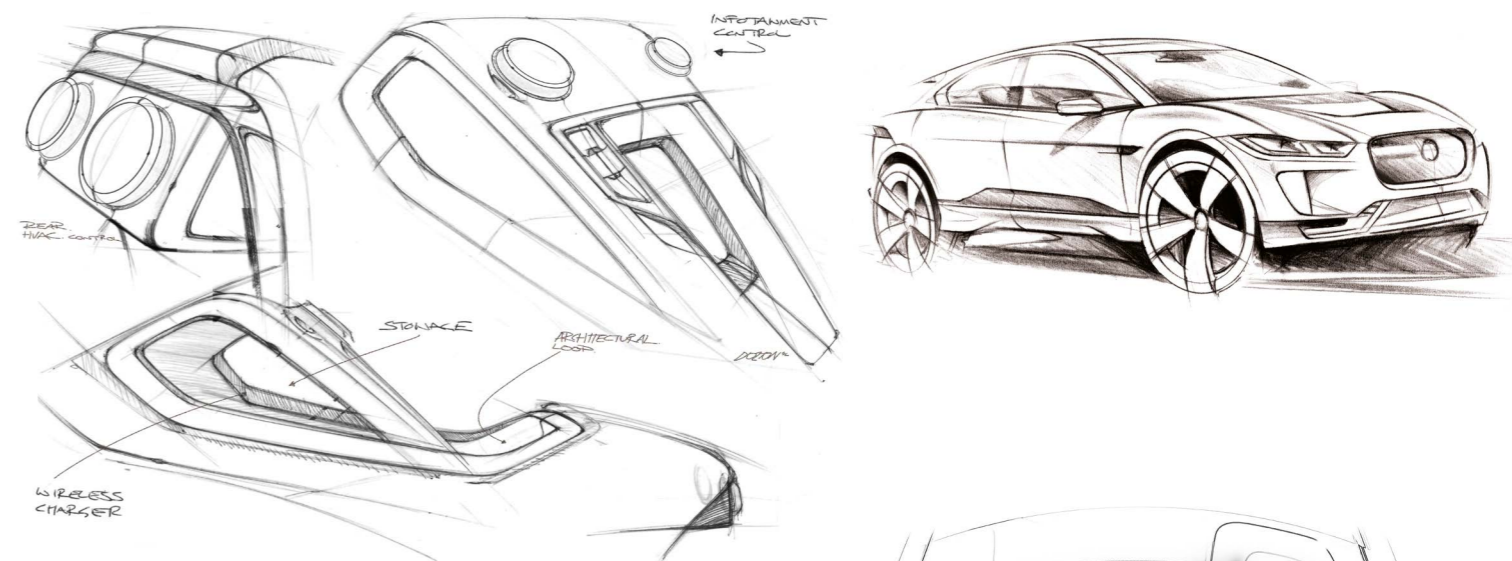
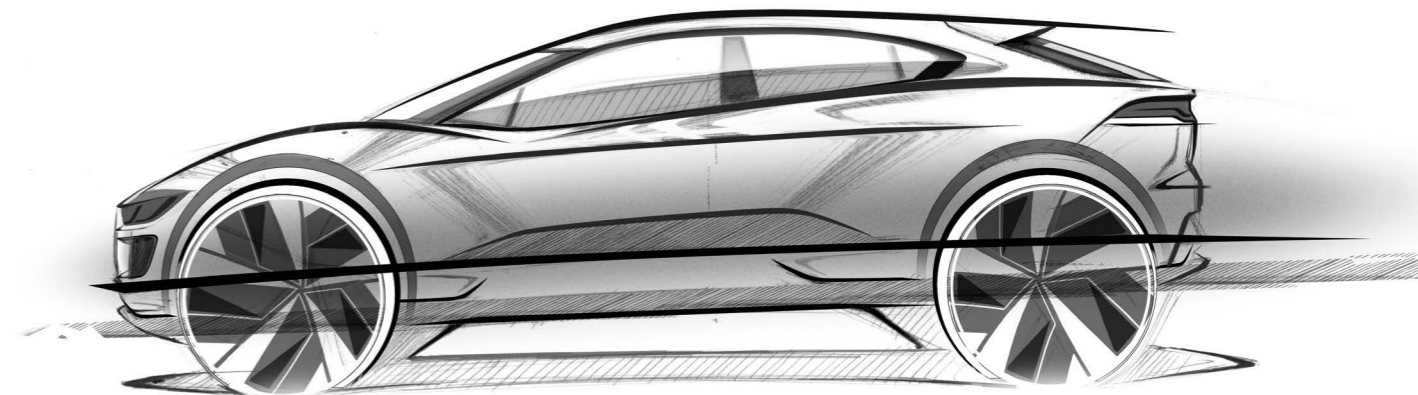
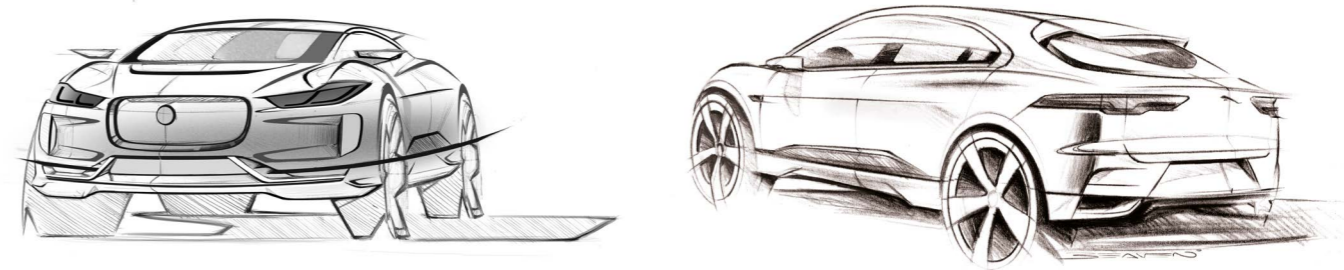



[JAGUARUSA.COM](http://JAGUARUSA.COM)

[MEDIA.JAGUAR.COM/EN-US](http://MEDIA.JAGUAR.COM/EN-US)