



THE NEW JAGUAR
E-SPACE



THE ART OF PERFORMANCE

"We are darers, performers and creators. Enemies to everydays and play-it-safers.

We are the heirs to greatness on road and track.

We never settle for less than extraordinary; pride-welling, pulse-quickenning moments when time stops and the world stares. Every Jaguar is a work of technical artistry; agile and sculptural, inspired and theatrical; a true performer that makes the road its stage.

Born of our flair, ingenuity and instinct for seduction, our creations embody our passion for performance and express our reason for being.

To excite in every sense.

So let our drivers sit spellbound in their front-row seats; as our engines roar out their symphonic score.

And let's show the world that true performance isn't just measured in figures, but in the way it makes you feel.

These are the moments worth living for, because it's not the number of breaths you take that matters, it's the moments that take your breath away."





AT A GLANCE

SPORTS CAR-INSPIRED DESIGN

Designed with distinctive, Jaguar proportions, short overhangs and powerful haunches.

WIRED FOR LIFE

Innovations and connectivity that make your life easier.

KEEPING IT IN THE FAMILY

Packed with Jaguar sports car genes.

THE ART OF PERFORMANCE

Jaguar's most playful model; feisty, agile, fun.

PRACTICALITY WITH PERSONALITY

A character that combines practicality with performance.





THE NEW JAGUAR E-PACE

The Jaguar E-PACE is a seriously smart compact SUV. Designed and engineered to be beautiful, fun and clever, it will introduce new fans to the brand. Instantly recognisable as a Jaguar, its undeniable sporting silhouette shrouds an interior that's been detailed to the tiniest degree, meaning the E-PACE not only looks beautiful but is practical and connected too.

Everything Jaguar has created with its award-winning range of saloons and sports cars and, of course, its World Car of the Year F-PACE SUV, has benefitted the E-PACE. It's a compact performance SUV featuring an all-wheel-drive system that is packed with technology designed to ensure the joy of driving a Jaguar whatever the conditions.

Inside, the E-PACE ensures you remain connected wherever life takes you. Using the very latest hardware and software developed in Jaguar's digital laboratories, it connects to your life and your devices, allowing seamless access to networks and data.

In short it's a perfectly 21st century car: connected, modern and practical, and utterly engaging to drive. It's beautiful to look at, fun to get to know and possessing a soul and integrity that can only come from Jaguar.



“ Every Jaguar is a work of technical artistry; agile and sculptural, inspired and theatrical; a true performer that makes the road its stage. ”

DESIGN

SPORTS CAR-INSPIRED DESIGN

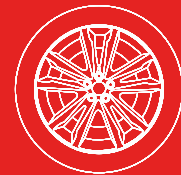

Optional
21-inch wheels



Powerful
rear haunches



J-Blade
daytime running lights



Jaguar
sports car DNA

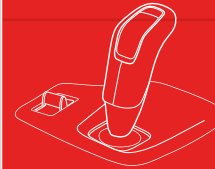

Sports gear shifter



Wraparound
cockpit

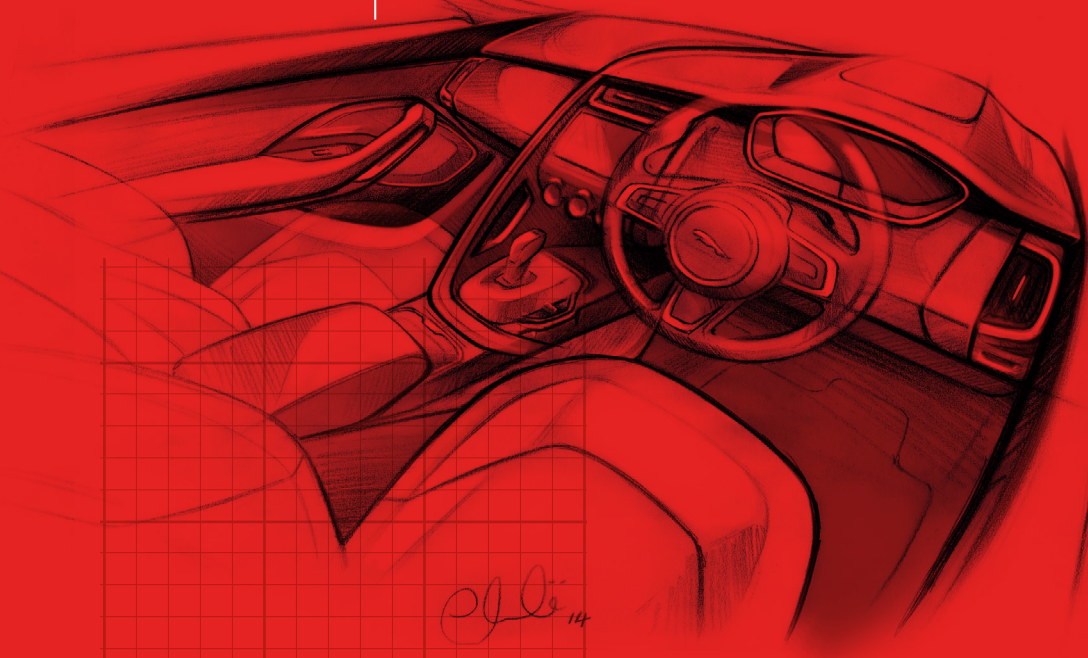

DESIGN

02 |

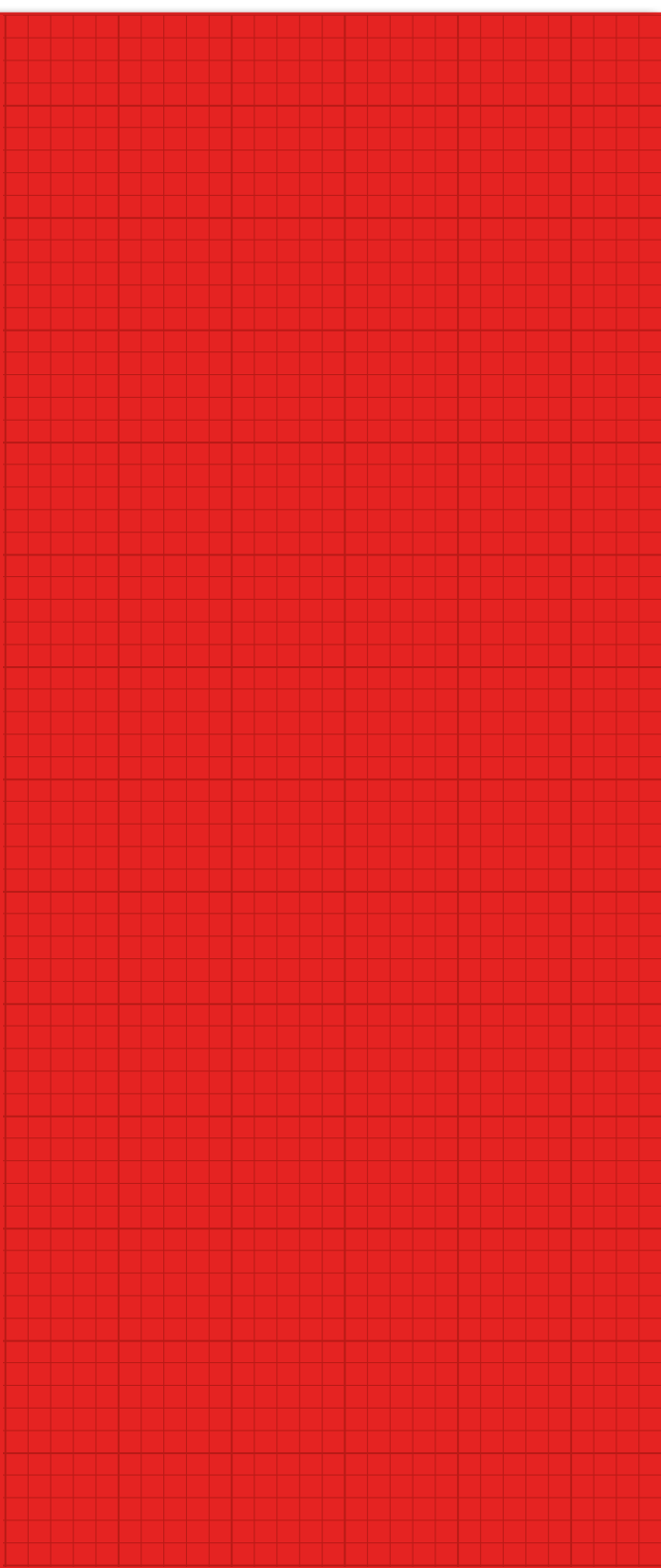

01 | SPORTS CAR-INSPIRED DESIGN



Just exactly what gives an object a certain edge can be hard to define. A stance? A swagger? A certain playfulness? Maybe something familiar, something in its silhouette, something hard to discern but which nonetheless stirs memories of a glorious bloodline?

The answer is most likely all of the above, only bound together by a certain confidence. The E-PACE is the fourth, all-new Jaguar in as many years and the most potent expression yet of rediscovered Jaguar relevance in the 21st century.

"Oh, it's got an attitude to it all right!" says Design Director Ian Callum of the new E-PACE, the most playful car in Jaguar's 81-year history, in many ways its most bold yet. "That's exactly how I wanted it; a balance of masculinity and femininity; not too genteel and certainly sensuous; muscular and curvaceous at the same time. That perfect Jaguar balance." E-PACE brings an uncommon sense of expressiveness to the compact SUV market.

Put simply, it is a much more evolved design; simultaneously more clever and more beautiful than is typical in the segment.

"It's important especially in a smaller car that aspires to a sense of heritage, and a heritage of performance, that it should have that certain attitude," says Callum. "In some ways the E-PACE is more like an F-TYPE than an F-PACE. Look at the haunches, front and rear, and the way the lines they make intersect, for example. Look at the profile of the roof in silhouette and the way it floats off the back. Look at the headlamps!"

It is testament to the clarity of Jaguar's contemporary design language that it so easily and effectively translates to a compact SUV. The essential energy of the fast-growing segment however has brought its own influences to bear and E-PACE introduces some new, evolved elements of that essential language, including a new 'chicane' light graphic inspired by the rush of seeing a racing car swoop left-right-right-left through a series of corners on a track.

And that essential exuberance and promise of dynamism is right here in E-PACE's short overhangs and long wheelbase, which themselves promise an unusual degree of comfort and practicality inside.

There is luxury too. Again with an eye on the sports car range, the inside of Jaguar's new cub offers a sense of command and control; dominant of the road, in touch with the car and spoiled with a quality of design and execution not seen before in this segment. Mixing premium leathers and technical surfaces picked up by effervescent, contrast stitching and sophisticated – and personalisable – interior lighting, E-PACE takes that unique Jaguar feeling to places it's never been before.

And 'cub', really? Take a close look. E-PACE most certainly represents a new generation of Jaguars, but one in which its proud parents have enormous confidence.

“ We designed the E-PACE to be a Jaguar for active people who need space and practicality, but see no reason to compromise on performance. Its proportions, stance and lines express this as a driver's car, while the interior offers true Jaguar levels of luxury and sportiness. ”

IAN CALLUM
DIRECTOR OF DESIGN, JAGUAR







DYNAMIC DNA
The sports car pedigree is most visible in the steeply-raked roof profile, large rear spoiler and optional 21-inch alloy wheels.



Creating a dynamic, modern and relevant interior continues the promise of the E-PACE's exterior character as soon as the doors are opened. The soft, high-quality materials used throughout the cabin are the first 'handshake' with the customer, while charming British detail design leaves a lasting memory. The E-PACE interior design raises the bar for the compact performance SUV.

ALISTER WHELAN
CREATIVE DIRECTOR, JAGUAR INTERIORS







FRONT-ROW SEATS

Body-hugging sports seats with contrasting stitching enhance the E-PACE's sporty streak, while soft grain Windsor leather brings out its distinctive side.



DESIGN IS IN THE DETAIL

The E-PACE is a practical Jaguar with a playful twist. Throughout the interior you will find details inspired by the Jaguar design team's favourite objects or experiences.

These small but beautiful details have been created to reflect the individual character and personality of the E-PACE, and like many premium products, they demonstrate an unwavering attention to detail.

From the tiny Jaguar and cub on the windscreen to the ever-so-subtle Jaguar print on the stowage mat, these hidden details are designed to put a smile on your face, once you notice them of course!



To see the hidden design details come to life, visit Jaguar's YouTube channel to watch the 'Jaguar E-PACE Design Film', which also features an interview with Ian Callum.

CUB GRAPHIC

Acknowledging the design team's internal name of the E-PACE - 'the cub' - the graphic on the windscreen and in the puddle lamp is a small detail designed simply to make owners smile.



CHICANE LINE

Jaguar has a rich racing heritage - dominating tracks such as Le Mans, and now in Formula E. The chicane line is a nod to Jaguar's racing pedigree; it's a line that represents movement and speed. You can see it on the tail lamp graphic and on top of the dashboard.



HEATING DIALS

To provide passengers with a tactile and precise touch point, a traditional 35mm camera lens inspired the design of the rotary ventilation dials.



STOWAGE MATS

Viewed from a certain perspective, the pattern on the E-PACE's front seat labels and rubber stowage mats appears purely decorative, but if you look closer you will see it is a series of horizontal and vertical lines that create the form of the Jaguar print graphic - like the skin of the wild animal.

🔗🔗 *Born of our flair, ingenuity and instinct for seduction, our creations embody a passion for performance and express our reason for being.* 🔗🔗



PERFORMANCE

THE ART OF PERFORMANCE



TORQUE SHIFT



ACTIVE DRIVELINE

All-wheel-drive system that offers you the best of both worlds - shifting up to 100% of the engine's torque to the rear axle to provide you with the character of a rear-wheel-drive car, or to the front axle to boost fuel efficiency.

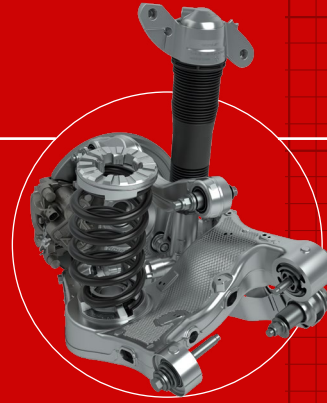

ADAPTIVE DYNAMICS

Continuously variable damper technology gives the perfect mix of handling response and body control. The latest triple-tube design adjusts damping force every 0.01 seconds.

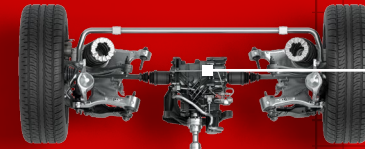

100%

Because it's a Jaguar, Active Driveline can shift all of the rear axle torque to the outside wheel during cornering, ensuring stability in all conditions.

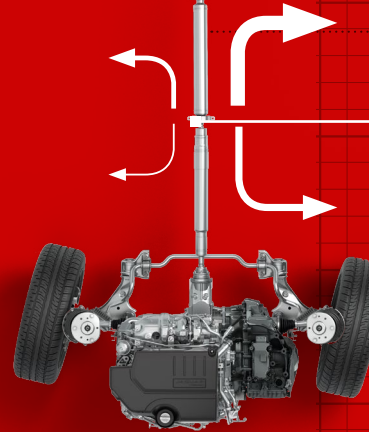

EVERY 10 MILLISECONDS

That's how frequently Active Driveline analyses driving and road conditions, calculating the optimum torque for each wheel.



PERFORMANCE

HQ1



02 | THE ART OF PERFORMANCE



If it looks like a Jaguar, it should drive like a Jaguar. The E-PACE won't disappoint anyone here – it's a Jaguar to its very core. Riding on an architecture and technology developed specially for a car of its size, proportion and purpose, its Integral Link rear suspension is shared with Jaguar's range of award-winning, 'great-to-ride-in-even-better-to-drive' saloon cars and F-PACE, reworked only to make it more compact still. That means more space inside and more space for the wheels to travel outside. The E-PACE is a compact SUV in more than just name.

All-wheel-drive E-PACE models come with a choice of Jaguar's new Active Driveline AWD system allowing them to be driven like any rear-wheel-drive Jaguar. So power-on oversteer and controlled drifts then. And Active Driveline isn't just there for play. In steady driving it disengages, meaning drive is supplied to the front wheels only, eradicating friction losses and boosting fuel efficiency. Re-coupling occurs in just 300 milliseconds.

Active Driveline joins a suite of recently introduced technologies all evolved for native application in the E-PACE. Configurable Dynamics is available allowing drivers of this compact SUV to head off-menu and set throttle and steering response, transmission shift speed and, if fitted, Adaptive Dynamics suspension to their own taste.

Adaptive Dynamics is capable of adjusting the E-PACE's damper settings every 10 milliseconds, reducing body roll and immediately prepping the vehicle for poor or no-road use as soon as a change in conditions is detected.

Jaguar Land Rover's highly-automated All Surface Progress Control – effectively launch and cruise control for less-than-ideal surfaces – is also available, as is brake-activated torque vectoring helping to maximise grip off-road and enhance stability in fast cornering when you're back on the highway.

And E-PACE never feels anything other than wide awake in its driver's hands thanks in part to its unique-to-Jaguar structure, mixing high-strength steel durability with lightweight aluminium and composites.



“With the E-PACE, our aim was to develop a Jaguar SUV that feels and responds with the character of any of our rear-wheel-drive vehicles. It was fundamental to us that E-PACE delivers exceptional drive dynamics, yet is refined and comfortable, and this was achieved with intelligent solutions, such as the compact Integral Link rear suspension and the semi-solid mounted front subframe. Here is an all-wheel-drive compact performance SUV that has the precision and body control to make the E-PACE as rewarding for the driver as it is comfortable for the passengers.”

MIKE CROSS
CHIEF ENGINEER OF VEHICLE INTEGRITY,
JAGUAR

The line-up of modern 2.0-litre diesel and petrol Jaguar Land Rover Ingenium engines range in output from 150PS to 300PS and comes with a choice of nine-speed automatic and six-speed manual transmissions in various front and AWD configurations.

The most compact car Jaguar has built yet, E-PACE has not been spared in a two-year development programme where its dynamic pre-eminence on-road has been established at a series of punishing locations such as the Nurbürgring and Nardò. Its off-road credentials have been tested to the limit too, both in the frozen landscapes of the Arctic and the thin air of some of China's most remote and highest regions.





FROM DEMANDING ROADS TO PUNISHING TEST TRACKS

Over the past months, Jaguar engineers have travelled around the globe to test the E-PACE in some of the world's most challenging environments - everything from snow and ice in the Arctic Circle to punishing laps around the Nürburgring - to make sure the vehicle is ready for the rigours of life in the real world.



TESTED TO EXTREMES: EXHAUSTIVE GLOBAL TEST PROGRAMME

- Sand** - Dubai, UAE
- Hot weather** - Arizona, USA; Dubai, UAE (+50C)
- Ice and snow** - Arjeplog, Sweden; International Falls, Minnesota (-30C)
- Performance and durability** - Nürburgring, Germany; Nardò, Italy; IDIADA, Spain
- Brakes** - Dolomites, Italy; IDIADA, Spain; Mojácar, Spain
- Altitude** - northern Chinese provinces; The Alps, Europe (up to 5,000 metres above sea level)
- Engine calibration** - Tenerife, Spain
- Noise, vibration and harshness** - Gaydon, UK
- All-surface conditions** - Walters Arena, Wales; Eastnor, UK



ALL INGENIUM POWER



INGENIUM PETROL

The E-PACE is available with a choice of two Si4 Ingenium petrol units delivering 249PS or 300PS. Both come with twin-scroll turbocharging, delivering faster throttle responses and virtually eliminating turbo lag.

INGENIUM DIESEL

Customers have a choice of three diesel options: a highly efficient 150PS Td4 unit, a more powerful 180PS Sd4 option and, at the top end, a high-performance 240PS Sd4 version producing 500Nm of torque.

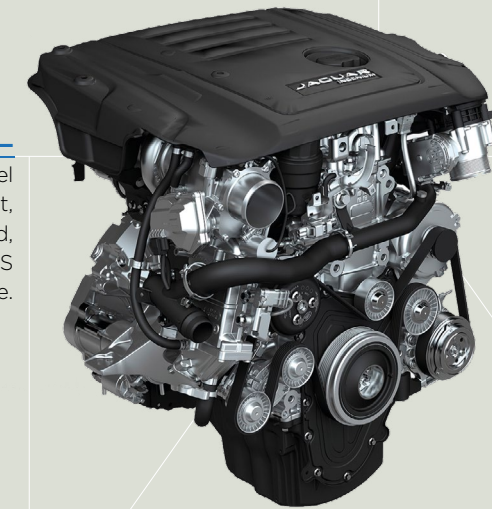

⌘⌘ *We never settle for less than extraordinary; pride-welling, pulse-quickenning moments; when time stops and the world stares.* ⌘⌘



WIRELESS

WIRED FOR LIFE



DIGITAL DISPLAY

Tailor the 12.3-inch high-definition full-colour display - you can even see your map in 3D.



UP TO 5 USB POINTS

A charge point for every occupant, plus up to four 12V power sockets - there's even one in the boot.



10-INCH TOUCHSCREEN



Imagine a customisable touchscreen that behaves just like your smartphone, offering the familiar swipe, pinch and pan functions. Jaguar's Touch Pro system makes this possible.

WEARABLE TECH

Waterproof wearable Activity Key for active lifestyles. Plus, connect your vehicle to your smart watch using the Remote Premium app to check fuel levels, lock status or location.

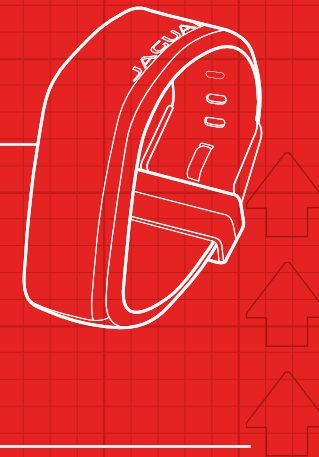

FULL COLOUR

Full-colour head-up display provides all the information you need, ensuring you never need to take your eyes off the road.

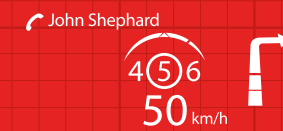

4G WI-FI HOTSPOT

Remain connected even when you're on the open road.



WIRELESS



DIGITAL DISPLAY

Tailor the 12.3-inch
full-colour display
see your map in 3

03 | WIRED FOR LIFE





You expect a Jaguar to have exceptional looks, drive and technology. The E-PACE is no different, a direct beneficiary of Jaguar Land Rover's unprecedented investment in digital technology. Powered by quad-core processors and networked using ultra-fast wireless and ethernet cable connections, the E-PACE is humming with clever thinking.

The E-PACE has a range of up to three new visual interfaces. Most dominant is the new 10-inch Touch Pro tablet, which allows you to touch, pinch, zoom and scroll through all your contacts, music, vehicle and navigation options. Meanwhile non-traditionalists can opt to have their analogue instruments replaced with a digital screen - a 12.3-inch, fully-configurable TFT panel. The third option is Jaguar's most advanced Head-Up Display, a TFT-powered, LED-illuminated, full-colour widescreen system capable of displaying more information with greater clarity directly in the driver's line of sight.

And the latest release of Touch Pro means there's a mass of real-time, location-driven information being sifted at any one time to ease the E-PACE and its driver through their daily commute (which, incidentally, is a feature of your life the E-PACE learns for itself). Or indeed a more ambitious journey, something you can of course plan 'offline' via your InControl smartphone app, which also facilitates remote vehicle status checks and locking, as well as journey history.

Of course, passengers are not ignored in the connected world of the E-PACE. There are USB connectors for all five occupants and further 12-volt charging points in the front, the centre console and even the boot.

There are two USB points in the central cubby box, which means you can connect a phone or tablet to control the car's 1280x542 pixel screen and optional Meridian premium sound system (including a 825-watt surround sound option) for your own, personal performance.

And Jaguar's smarts don't just make the E-PACE better connected. It makes it more helpful and safer too, with a range of options including Blind Spot Assist and Autonomous Emergency Braking powered respectively by rear- and forward-looking cameras that will trigger steering or brake interventions to keep you out of harm's way. The same systems power the E-PACE's optional Adaptive Cruise Control with Queue Assist to keep you a safe distance from the vehicle in front and Park Assist that takes over the steering function entirely in tight parking manoeuvres.

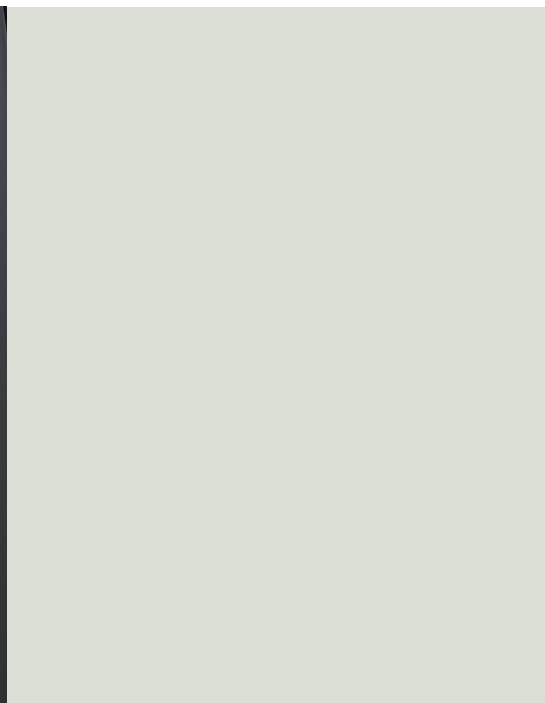

A DESIGN FOR LIFE

Wherever in the world you might be, InControl Remote allows you to stay in touch with your vehicle. If you've forgotten where you've parked, your app will help you find it and if it's cold outside, you can pre-set the climate control in the cabin to ensure it's ready for your arrival.

John Shephard

4 5 6
50 km/h



SAFETY IN NUMBERS

E-PACE is packed full of active and passive safety technologies that keep you and your family safe. Head-Up Display helps you keep your eyes on the road, while the forward-facing camera detects anything you might miss. In the event of a collision, six airbags and two ISOFIX points protect occupants while a pedestrian airbag reduces injury to others.

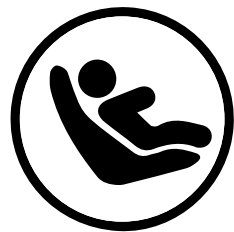

ISOFIX

⌘⌘ *We are darers,
performers and creators.
Enemies to everydayers
and play-it-safers.* ⌘⌘

5
PRACTICALITY
WITH PERSONALITY



PRACTICALITY WITH PERSONALITY



LOAD IT UP

Because your essentials are exactly that, the main luggage area can accommodate your golf clubs or pram or six carry-on flight suitcases. There's a total of 577 litres with the seats up, or a spacious 1,234 litres with the 60:40 split rear seats folded.

LIGHT THE WAY

Adaptive Matrix LED headlamps, featuring a sweeping flash indicator, provide you with superior illumination of the road ahead.

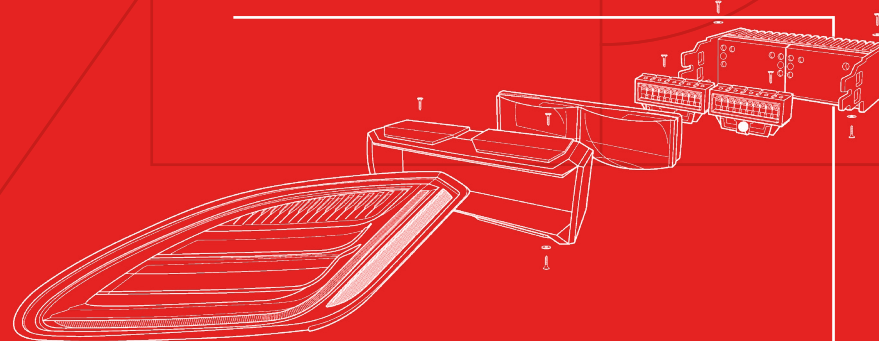

DRINK IT IN

At 8.5 litres, the centre console is designed to fit two, one-litre bottles lying flat - with room to spare. There is more than 40 litres of stowage inside overall, including a 10-litre glovebox.

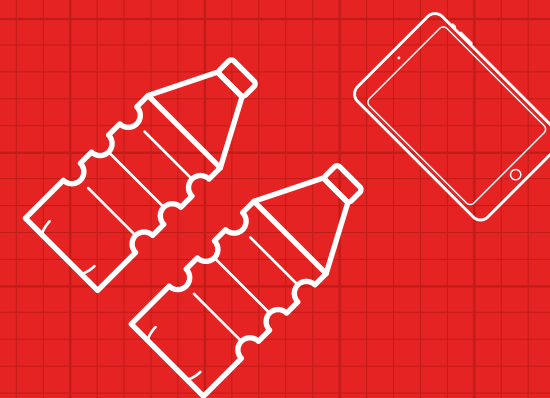

UTILITY



150

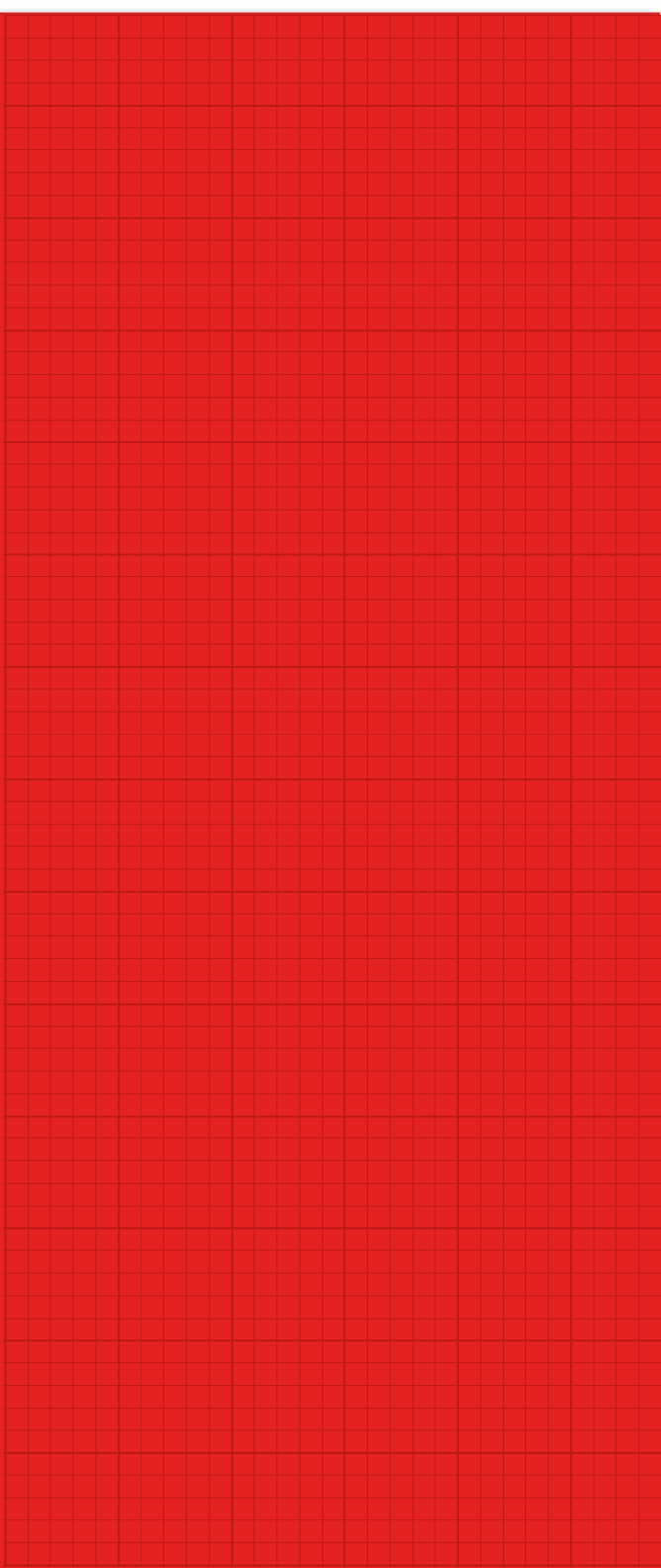

04 | PRACTICALITY WITH PERSONALITY



There was, of course, no point in creating the Jaguar of the compact SUV class - better looking, better to drive, better connected - if the team involved didn't simultaneously re-address the vehicle's reason-to-be - providing a practical, versatile platform for busy, colourful, always-on lives.

The process starts with the fundamentals. From wheel-centre to wheel-centre the E-PACE measures 2,681mm, a fact that, in combination with the compact Integral Link rear suspension, means passengers in the rear will get a real sense of light and space, with more rear legroom than some larger SUVs.

LITRES AND LITRES OF SPACE

8.42 | CENTRAL STOWAGE COMPARTMENT

10.07 | GLOVEBOX

577 | BOOT SPACE

1,234 | LUGGAGE SPACE WITH REAR SEATS FOLDED

So, Jaguar started with a bigger, better space and then the designers started thinking about how to make it work for families and individuals who don't sit at home. There is, for example, a cavernous 8.4-litre central stowage compartment between the front seats that will swallow two, one-litre water bottles with space left over for smartphones and tablets-on-charge, both of which have their own places to live. There's even a net under the lid of the compartment for smaller items.

And it doesn't stop there. There's another 10 litres of space in the glovebox and almost the same in the two front door bins. In the boot there's 577 litres of luggage space, or the equivalent of six carry-on cases. That's with the rear seats in place. Fold them and the space more than triples to 1,234 litres. Fold the narrower of the 40:60 split seats and there's room for 1.6-metre-long objects as well as two passengers.



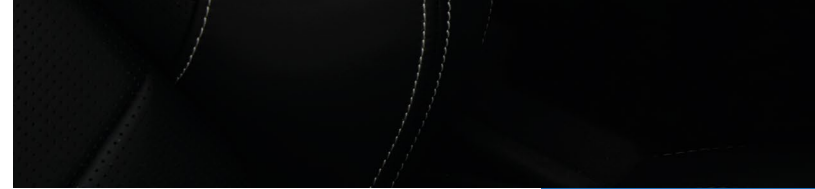

SMART STORAGE

If proof were ever needed that practicality can be stylish, then step inside the E-PACE. Cleverly designed and beautifully finished storage options include a central cubby box that can hold a tablet securely - there's also space between the configurable drinks holders for a smartphone.



But it's not just all about big numbers. Convenience is a big feature too. For example, the E-PACE is available with Gesture Tailgate technology, which means you don't need to be able to reach in your pocket for the key when you want to open the boot, just use your foot. And there's Jaguar's Activity Key for the most active customers; fully waterproof and shockproof, it's a high-tech wristband that you can substitute for the conventional key when that's just not practical.

So whether it's nine-to-five or five-til-bedtime - or indeed both - the E-PACE, the most desirable and exciting compact SUV, has your back.

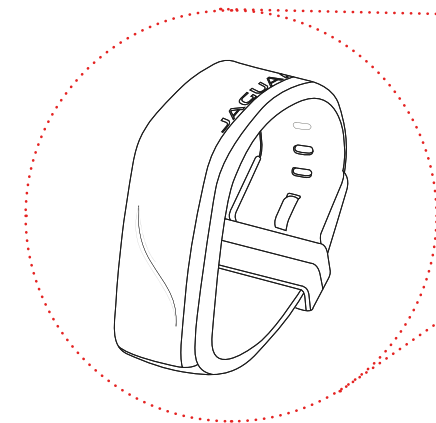

10.56-LITRE FRONT
AND **8.26-LITRE** REAR DOOR BINS





KEEPING IT IN THE FAMILY



The E-PACE is the newest addition to Jaguar's PACE family; a range of vehicles that combine performance with practicality. The F-PACE performance SUV pioneered the brand into the SUV segment and has led the transformational sales charge for Jaguar, becoming its fastest-selling model to date.

The Jaguar I-PACE Concept is the company's first all-electric performance SUV and previews the production vehicle that will hit the road in 2018.

The E-PACE compact performance SUV delivers Jaguar's trademark driving DNA, a design language that's inspired by its sports car range with the space and practicality of the PACE family.

RANGE SUMMARY

TWO MODELS,
THREE SPECIFICATION PACKS
AND FIVE POWERTRAINS.

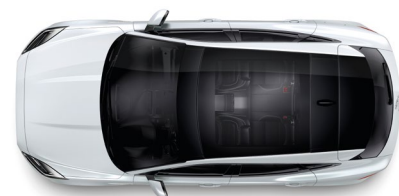

Both the E-PACE and E-PACE R-Dynamic are available with S, SE and HSE specification packs and a choice of five powertrains, including three diesel and two petrol Ingenium engines. The 2.0-litre four-cylinder Ingenium diesel powerplant is available in 150PS, 180PS and 240PS outputs, while the pair of 2.0-litre four-cylinder Ingenium petrol turbo units deliver 249PS or 300PS.

High levels of standard equipment are a core component of the E-PACE range. Convenience features such as Touch Pro infotainment and All-Surface Progress Control are joined by safety kit including Driver Condition Monitoring, Autonomous Emergency Braking and LED headlights with signature DRL.

ROOF WITH A VIEW

Choose from four different roof designs, including a black, fixed panoramic roof that creates a lighter, more airy feel to the cabin.

E-PACE



E-PACE R-DYNAMIC





LIGHTING THE WAY

First Edition models feature the cub-to-Jaguar puddle lamp. Not only does it chart the evolution of the Jaguar but also helps guide you to the door of your E-PACE.



FIRST EDITION

AVAILABLE FOR THE FIRST FULL YEAR OF SALES, THE E-PACE FIRST EDITION FEATURES A UNIQUE, PERFORMANCE-FOCUSED SPECIFICATION.

The E-PACE First Edition is powered exclusively by Jaguar's 180PS Ingenium diesel or 249PS Ingenium petrol engines paired with the nine-speed ZF automatic transmission. These limited edition models are carefully specified to showcase the E-PACE's unique design, performance and practicality and are based on the R-Dynamic derivative fitted with an SE specification pack.

Three colour options are available - Caldera Red, which is unique to the First Edition, Yulong White and Santorini Black. Gloss Black detailing and distinctive 20-inch Satin Grey diamond-turned, six-split-spoke alloy wheels complete the look.

Inside, a special soft grain Windsor leather interior in Ebony with red contrast stitching and an Ebony suedecloth headlining give the cabin a distinctive appearance. Configurable ambient mood lighting and the natural light from the panoramic roof perfectly complement the spacious interior. Jaguar's TFT head-up display, additional charging points and load space rails ensure the First Edition provides a seamless blend of refinement, technology and real-world practicality.

Additional highlights include Configurable Dynamics, a gesture-controlled tailgate and Jaguar Activity Key, along with unique First Edition carpet mats and metal treadplates.



	D150 FWD	D150 AWD	D150 AWD	D180 AWD	D180 AWD	D240 AWD	P250 AWD	P300 AWD
Transmission	Manual	Manual	Automatic	Manual	Automatic	Automatic	Automatic	Automatic
Height (mm)	1649							
Width wing mirrors folded / wing mirrors out (mm)	1984 / 2088							
Length (mm)	4395							
Wheelbase (mm)	2681							
Wading depth (mm)	500							
Drag coefficient (Cd)	0.325	0.325	0.325	0.325	0.325	0.34	0.34	0.36
Weight EU unladen (kg)	1775	1831	1843	1831	1843	1926	1832	1894
Front suspension	MacPherson strut with lower control arm, coil springs, passive dampers and passive anti-roll bar							
Rear suspension	Integral multi-link with coil springs, passive dampers and passive anti-roll bar							
Steering	Electronic Power Assisted Steering (EPAS) rack and pinion							
Brakes Front / Rear (mm)	325 / 300	325 / 300	325 / 300	325 / 300	325 / 300	349 / 300	325 (17" only) / 349 / 300	349 / 300
Displacement (cc)	1999	1999	1999	1999	1999	1999	1998	1998
Bore / stroke (mm)	83 / 92.3	83 / 92.3	83 / 92.3	83 / 92.3	83 / 92.3	83 / 92.3	83 / 92.3	83 / 92.3
Compression ratio	15.5:1	15.5:1	15.5:1	15.5:1	15.5:1	15.34:1	10.5 +/- 0.5:1	10.5 +/- 0.5:1
Max Power (PS / kW)	150 / 110	150 / 110	150 / 110	180 / 132	180 / 132	240 / 177	249 / 183	300 / 221
Max Torque (Nm)	380	380	380	430	430	500	365	400
CO₂ EU Combined (g/km)	124 (17" wheel) 129 (18"-21")	137	147	137	147	162	174	181
Fuel Consumption EU Combined (MPG)	60.1 (17" wheel) 55.7 (18"-21")	54.3	50.4	54.3	50.4	45.6	36.7	35.3
Fuel tank capacity (usable litres)	55.7	55.7	55.7	55.7	55.7	55.7	68.5	68.5
0-60mph / 0-100km/h (secs)	9.5 / 10.1	10.1 / 10.7	9.9 / 10.5	9.4 / 9.9	8.7 / 9.3	7.0 / 7.4	6.6 / 7.0	5.9 / 6.4
Top speed (mph / km/h)	124 / 199	120 / 194	120 / 193	128 / 207	127 / 205	139 / 224	143 / 230	151 / 243

*Manufacturer's estimated figures

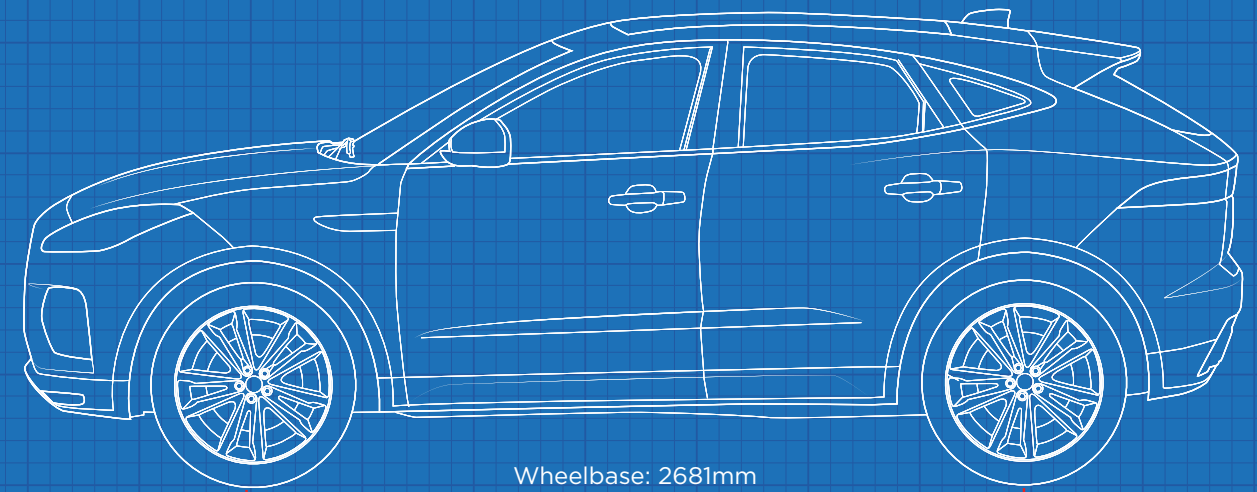

Wheelbase: 2681mm

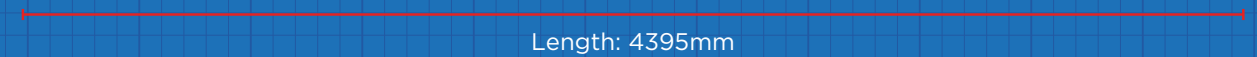

Length: 4395mm

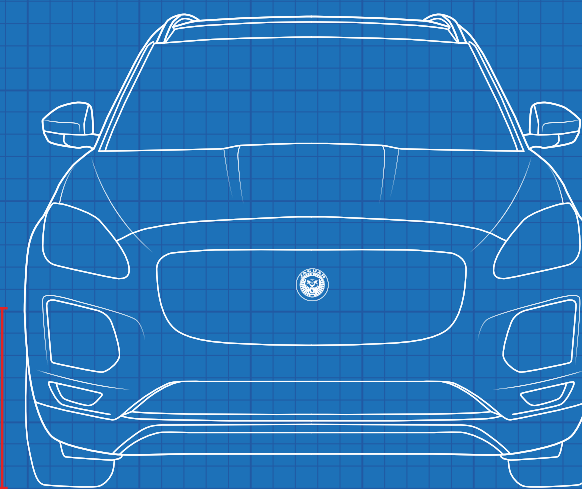

Wading Depth:
500mm

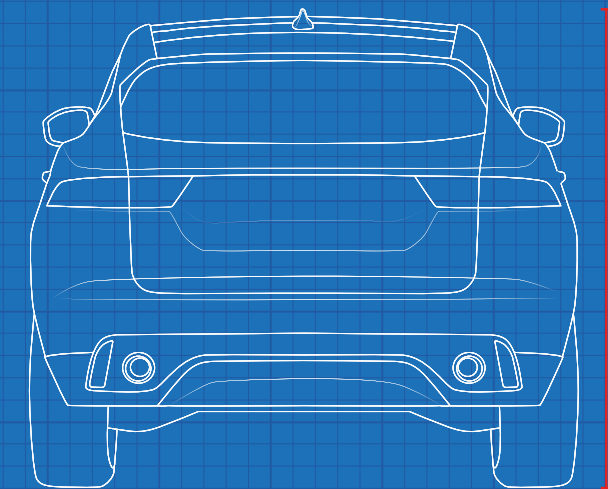

Height:
1649mm



Width: 1984mm

FIRST IMAGE IN A SERIES OF URBAN E-PACE ART
FROM CGI ARTIST CHRIS LABROOY.





